



## SCST : LED SLIM CANOPY

### DESCRIPTION

The SCST features a streamlined appearance and straight-forward mounting features that allow for surface or pendant mounting in a wide variety of applications.

### FEATURES

- Low-profile and lightweight die-cast aluminum housing
- Built-in features and internal driver allow for surface mounting or pendant mounting to 3/4" NPS stem

### LISTINGS

- UL Listed for wet locations
- DesignLights Consortium® Qualified - meets DLC requirements for efficacy and lumen maintenance
- IP65 Rated
- ROHS Compliant

### PERFORMANCE

- Rated lifetime L70: 60,000 hours
- 14,000lm @ 127W (110 lpw)
- 16,000lm @ 145W (110 lpw)
- 5000K CCT
- CRI: 80+

### ELECTRICAL

- Input voltage: 120-277V; 200-480V
- Power Factor: >0.90
- THD: <20%

### THERMAL

- -40°F to 113°F (-40°C to 45°C) operating temperature

### CONSTRUCTION

- Polyester powder coating protects against environmental changes without peeling or cracking (consult factory for other color options)
- Pre-wired with 3' cable

### WARRANTY

- 5 year limited warranty; see eiko.com for warranty details

project name	type
catalog number	
comments	voltage
approved by	date



### APPLICATIONS

- Gas station canopies
- Drive-thru and other canopy applications
- Loading docks
- Mass transit depots



## ORDERING INFORMATION

EXAMPLE: SCST-140/B0/850-U-W

Model	Package	LPW	CRI/CCT	Voltage	Finish
SCST : LED Slim Canopy	<b>140</b> - 14,000 lm <b>160</b> - 16,000 lm	<b>B0</b> - 110 lpw	<b>850K</b> - 80+ CRI; 5000K	<b>U</b> - 120-277V <b>V</b> - 200-480V	<b>W</b> - White

## PERFORMANCE SUMMARY

Order Code	Item #	Watts	Lumens	CCT	CRI	Volts	HID Equiv.	DLC
09952	SCST-140/B0/850-U-W	127W	14,000	5000K	80+	120-277V	250-400W	✓
09953	SCST-140/B0/850-V-W	127W	14,000	5000K	80+	200-480V	250-400W	✓
09954	SCST-160/B0/850-U-W	145W	16,000	5000K	80+	120-277V	400-600W	✓

## DIMENSIONS

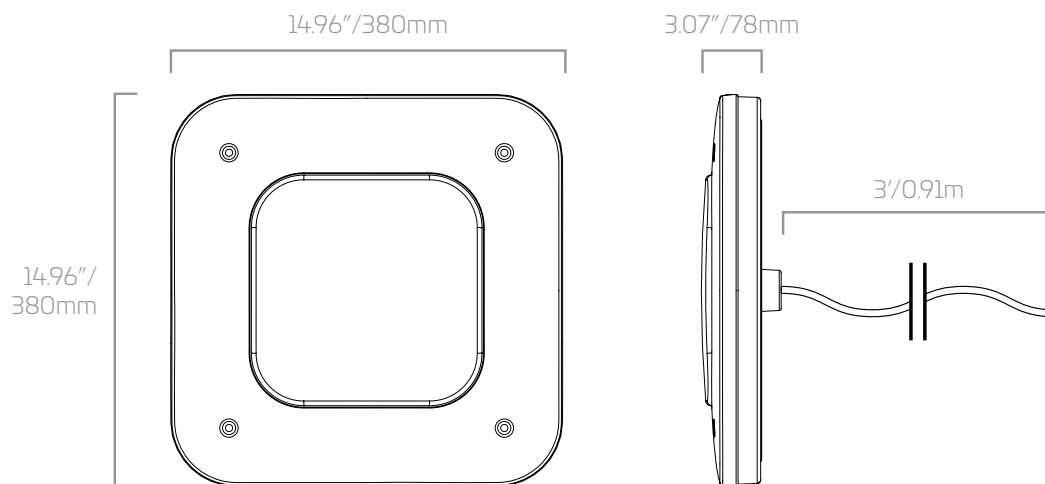

# PHOTOMETRICS

## SCST-140

ZONAL LUMEN SUMMARY		
Zone	Lumens	%Fixture
0-30	3933.5	27.5%
0-40	6537.8	45.8%
0-60	11610.1	81.2%
60-90	2651.5	18.6%
70-100	1012.0	7.1%
90-120	7.6	0.1%
0-90	14261.6	99.8%
90-180	278	0.2%
0-180	14289.5	100%

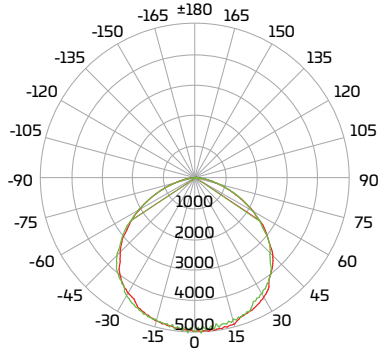

AVERAGE BEAM ANGLE (50%) : 112.5°

UNIT : cd  
— C0-180, 56.4, 56.2  
— C90-270, 56.5, 55.9

## SCST-160

ZONAL LUMEN SUMMARY		
Zone	Lumens	%Fixture
0-30	4526.9	27.5%
0-40	7517.1	45.7%
0-60	13354.3	81.3%
60-90	3045.6	18.5%
70-100	1163.2	7.1%
90-120	9.2	0.1%
0-90	16399.9	99.8%
90-180	33.2	0.2%
0-180	16433.1	100%

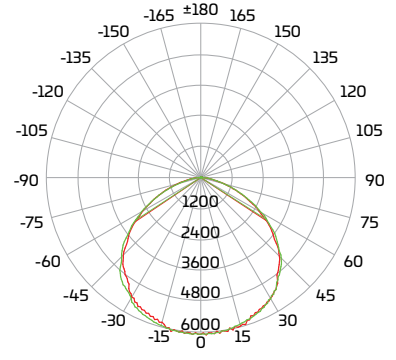

AVERAGE BEAM ANGLE (50%) : 113.4°

UNIT : cd  
— C0-180, 56.0, 56.7  
— C90-270, 56.8, 57.4

## BUG RATINGS

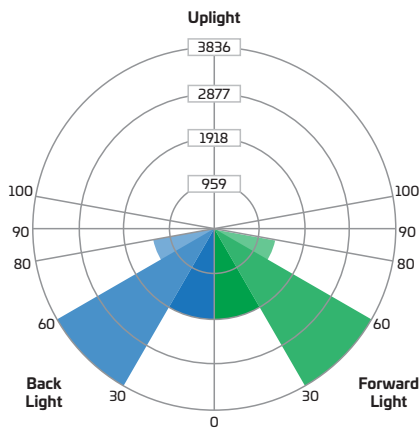

**SCST-140**  
B3-U2-G2

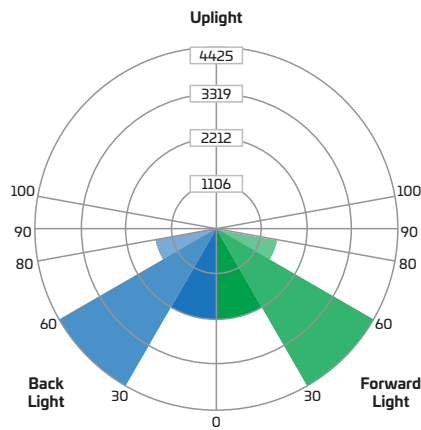

**SCST-160**  
B3-U2-G2